



Version: 5.10.S002

SMART INDUSTRIAL BATTERY CHARGER (QZA36360L3) USER MANUAL



SONEIL INTERNATIONAL LTD.

TEL: 905-565-0360

FAX: 905-565-0342

29-6033, Shawson Drive, Mississauga

ON, L5T 1H8 Canada

Web: www.soneil.com

Email: info@soneil.com

Introduction

QZA series smart battery charger is latest in switch-mode battery charger technology. The inside micro-controller controls the whole charge procedure. Friendly user interface, LCD display and key input, makes it easy to use.



QZA36360L3

QZA36360L3 supports different charge curves, makes a complete charge and long battery life and has all-around protections.

QZA36360L3 is high frequency switching mode charger. IGBT and PWM controller are the main components. Soft switching technology (resonant zero voltage switching and zero current switching) increases the efficiency and reduces electromagnetic interference.

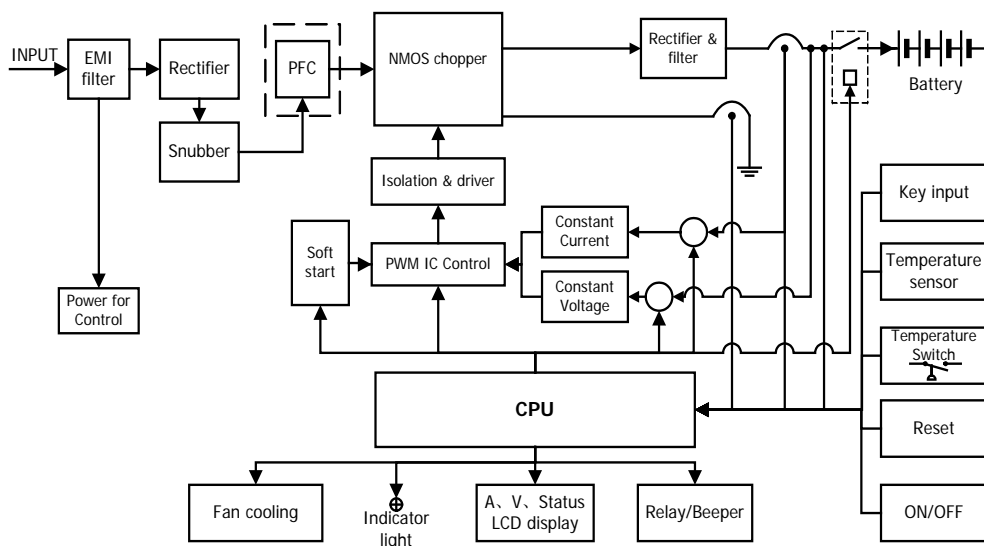

Diagram 1. Block diagram of QZA36360L3
QZA36360L3 charger can be widely used in Marine, e-forklift, railway vehicle, and many other places for all kinds of battery.

1. Technique Specifications

- (1) Power supply: AC 3 ϕ 480V, +/-10%, 50/60Hz.
- (2) Outputs: max current, 180A@44.1VDC (27-180A adjustable)
max voltage, 48.6VDC (12.0-48.6V adjustable)
- (3) User interface:
LCD display and key input
voltage display precision: 0.1V; amps display precision: 1A
- (4) Set charging parameter precision:
voltage: 0.1V; current: 1A
- (5) Charge curve:

(5-1) 3-stage charge

A: limited current / Boost, B: Constant Voltage, C: floating

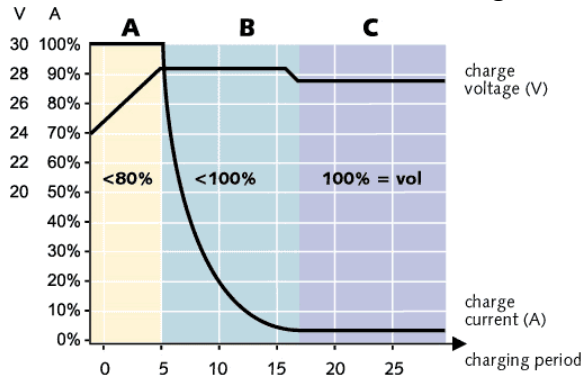

Diagram 2. Three stage recharge voltage/current curve.

(5-2) 4-stage charge

A: Constant current 1(C.C.1), B: Constant Voltage 1(C.V.1), C: C.C. 2, D: C. V. 2

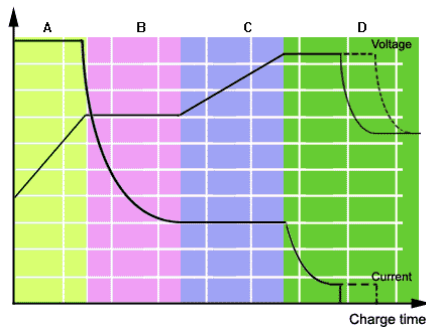

Diagram 3. Four stage recharge voltage/current curve.

- (6) Protection and Alarm:
- Over voltage protection, Over load protection,
 - Input voltage low/input phase loss protection,
 - Input fuse protection.
 - Battery reverse connection protection with output fuse;
 - Diode in output line to eliminate spark.
 - Output power limitation,
 - Temperature control fan cooling (about 45°C)
 - Reduce output power (about 75°C -78°C), resume (about 65°C)
 - Over temperature protection (about 80°C -85°C) (stop and auto restart)
 - Password for parameter setting.
- (7) Low ripple, 0.3% of the charge voltage
- (8) PFC. $\cos\Phi > 0.94$.
- (9) PC remote control with RS-232
- (10) Charge efficiency: 90%
- (11) Operating temperature range: 0~50°C (32~122°F)
- (12) Safety class: IP20.
- (13) Dimension: 520*508*214mm(W*D*H)

2. Panels

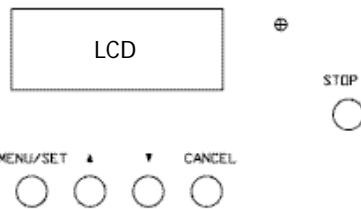

Diagram 4: Front panel.
LCD, buttons and

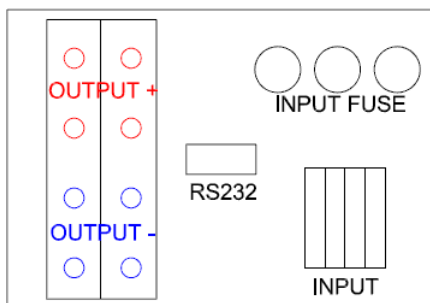

Diagram 5: Back panel.
Input & Output
terminals, input fuses
and RS-232 port

3. Installation and Operations:

- (1) Ensure a clearance of at least 10 cm around the battery charger to ensure adequate ventilation.
- (2) The battery charger must not be installed in the vicinity of heat sources or exposed to water.
- (3) Ventilation slots must not be obstructed.
- (4) Connect input wires and the GND. Then turn on the AC power. LCD shows output voltage, current in the first line and the status of charger in the second line.
- (5) Set the charge parameters.

(6.1) Press “Menu/Set” to enter the menu.

Then press ▲ ▼ to choose item; or
Press “Back/Cancel”, quit the menu.

(6.2) choose an item; press “Menu/Set”, the value will flash.

Then press ▲ ▼ to increase or decrease the value.
Then press “Menu/Set”, save the new value; or
Press “Back/Cancel” back to menu without save.

(6.3) Password is required when enter the menu. If password is accepted, user can modify the values; if password is denied, user can view the values only. The default password is “000”.

(6) 3-stage charge parameter set.

1. Set floating voltage.
2. Set the constant current.
3. Set the constant/equalize voltage.
4. Set the current value to floating charge, when output current is not higher than this value.
5. Set the floating charge delay time.
0, 1, 2, 3 hours or NO STOP.
If set “NO STOP”, floating charge until equalize day (See item 7.).
6. Set the over voltage protection value
7. Set the cycle time of equalize charge.
Item 5, Delay time, should be set to “NO STOP”.
8. Set voltage values for LA, AGM or GEL battery.
9. Choose charging curve 3-stage or 4-stage
10. Set all to default values (LA battery, 3-stage curve).

Enter Password ***

Password Okay.

Password invalid

11. Set new password.
12. Choose nominal voltage for different voltage battery. The charge voltages will change automatically.
13. Not available.

(7) 4-stage charge parameter set.

1. Set the constant current 1.
2. Set the constant voltage 1.
3. Set the constant current 2.
4. Set the constant voltage 2.
5. Set the delay time, after voltage equals to C.V.2.
0, 1, 2, 3 or 4 hours.
6. Set the over voltage protection value
7. Not available.
8. Choose battery. Flooded LA, GEN GEL LA, AGM SEALED LA, Tubular LA. Voltage and current will be changed automatically.

Default values	CC1 per 100Ah	CV1 per cell	CC2 per 100Ah
Flooded Regular LA	18A	2.37V	5A
GEN GEL Sealed LA	16A	2.4V	1.5A
AGM Sealed LA	15.5A	2.37V	3A
Tubular LA	18A	2.45V	5A

CV2 is 2.7V/cell for these 4 batteries.

9. Choose charging curve 3-stage or 4-stage
10. Set all to default values (LA battery, 3-stage curve).
11. Set new password.
12. Choose nominal voltage for different voltage battery. The charge voltages will change automatically.
13. Set battery capacity, then the current value will be changed automatically.

Set parameters by buttons when the charger is in the status: Stop Charge.

(8) Connect the battery. Be careful and **do NOT reverse the poles “+” and “-”**. Connect the battery; the charger is going to work automatically.

Status	Display	Indicator	Relay/Beeper	
Constant current	Equalize charge	Yellow flash		3-stage
Constant voltage	Constant volt	Yellow light		
Floating charge	Floating charge	Green flash		
Constant current 1	CC1	Yellow flash		4-stage
Constant voltage 1	CV1	Yellow flash		
Constant current 2	CC2	Yellow flash		
Constant voltage 2	CV2	Yellow light		
Charge complete.	COMPLETED	Green flash	Act & stop charge	
Over volt protection	OVER VOLTAGE	Red flash	Act & stop charge	Manually restart
Over Load protection	OVER LOAD			Auto restart
Over temperature protection (80°C -85°C)	OVER HEATING			(If restart 3 times in 1 minute, manually restart.)
AC input voltage low Input phase loss protection	INPUT ABNORMAL			
Stop charge	Stop charge	Green light		

Table 1. Charger status list

(9) Press ▲ ▼ buttons to see the charging time. be kept until another charge starts.

026.7V	008A
00D 06H	15M

(10)The charger has **DC active, Auto-stop and Soft limit-current start** function.

DC active: Connect the battery. When the voltage rises from lower to higher than 1/2 of the Nominal voltage (eg. 6V of 12V battery, 18V of 36V battery), the charger will start to charge.

Soft limit-current start: When it starts, the current limitation is 60% of the constant current value, and the limitation increases about 1-2 Amp per second until it equals to constant current value.

Auto-stop: When the current is less than or equals to 1 Amps. The charger will stop in 3 seconds.

Note: Disconnect a battery; user should wait at least 15 seconds to connect another. The output voltage decreases slowly. After it is less than 1/2 of the Nominal voltage, the **DC active** will be available again. If the voltage does not decrease to lower than 1/2 of the Nominal voltage, when connecting, charging will **NOT** start automatically.

(11) Stop and alarm

- When **over voltage** and **over load** protection occurs, the charger will stop and alarm. The indicator is red and flash.
- When **over temperature** or **AC input voltage low** protection occurs, the charger will stop and alarm. The indicator is red and flash. When resume, it will restart automatically.
- When **over load** or **AC input voltage low/phase loss** protection acts, the charger will try to restart 3 times. If it protects more than 3 times in 1 minute, it will not restart again until 1 hour. User can restart charge manually.
- Press “Menu/Set” key to acknowledge the alarm and press “Back/Cancel” key to restart charge manually.
- When charge is **completed**, it will stop and alarm. The indicator is green and flash.
- Alarm relay or beeper is not available.

(12) Press “STOP” button to stop the charge for emergency. The charger will not start in any condition. Unless user cut off and turn on the AC power again.

(13) RS-232 port for remote control. Please see RS232 communication document.

BIG CHARGERS DETAILS

Appendix 1: Standard types and dimensions

C. \ V.	12V	24V	36V	48V	60V	72V	80V	96V	108V	192V	216V
3A											A
5A										A	B
10A				A	A	A	A	A	B	B	C
15A			A			B		B	B	C	C
20A		A		A	B	B	C	C	C	D	D
25A			A			C		C	C	D	D
30A	A	A		B	C	C	C	C	D	E	E
40A	A	A	B	C	C	C	D	D	D	E	E
50A	A	B	C	C	C	D	D	D	E		
60A	A	B	C	C	D	D	D	E	E		
70A	B	C	C	D	D	D	D	E	E		
80A	B	C	C	D	D	D	E	E			
90A	B	C	D	D	D	E	E				
100A	B	C	D	D	E	E	E				
120A	C	C	D	D	E	E					
130A	C	D	D	E							
150A	C	D	D	E							
180A	C	E	E								
200A	C	E	E								

	Dimensions (mm)	Weight (KG)
A	Bench mount, 350×243×113 mm	6
B	Bench mount, 370×310×113mm	8
C	Bench mount, 460×350×128 mm	10
D	Bench mount, 520×380×150 mm	20
E	Bench mount, 550×430×160 mm	25
12KW-20KW	600(W)x300(L)x1000(H)mm.	60-90

Appendix 2: Default voltage, for 3-stage curve.

Battery Nominal Voltage		12V	24V	48V	60V	72V	80V	216V
LA/VRLA/GEL	Floating	13.5V	27.0V	54.0V	67.5V	81.0V	90.0V	243V
	Equalize	14.2V	28.4V	56.8V	71.0V	85.2V	94.7V	256V
AGM	Floating	13.8V	27.6V	55.2V	69.0V	82.8V	92.0V	248V
	Equalize	14.5V	29.0V	58.0V	72.5V	87.0V	96.7V	261V

AGM: Absorbed Glass Matt

Appendix 3: Output Fuse information: See www.bussmann.com.

British style 88 fuse

Nominal Current	50A	60A	80A	100A	120A	150A	200A
Fuse	50LET	63LET	80LET	100LET	125LET	160LET	200LMT

Note: Specifications is subject to change without notice.

Ref: Main Fold-Product Specs >75A-SICM052710